

HYBRID INVERTERS

HIS

Single-phase hybrid inverter for batteries and grid or emergency generator

Description



The range of HIS hybrid inverters is designed to meet power requirements in locations not covered by the grid or where electricity is very expensive.

The main feature of hybrid HIS inverters is that they are capable of generating electricity from Batteries, from the Grid or Emergency Generator, in a controlled manner.

Hybrid HIS inverters combine the power from a fossil fuel to the DC resource, prioritising the consumption from DC energies over the rest.

This function allows high energy savings in installations fitted with an emergency power generator. Optionally, they implement management strategies oriented towards energy saving.



HIS 6 & 8 models

Features

- > Grid or Emergency Generators Input
- > Wind Turbine and PV field compatible through external battery charge regulator
- > Back-up battery
- > Very low harmonic distortion THD< 3%
- > Monitoring from the unit with LCD
- > Galvanic isolation via transformer
- > IP21 protection level
- > Protection against: Inverse polarity, short circuits, overvoltages, isolation failure with relay output
- > As back-up or for clients with high power availability requirements: Telecom installations, IT installations
- > ECO mode available: inverter will not work if there's no consumption
- > Output to start external emergency Generation

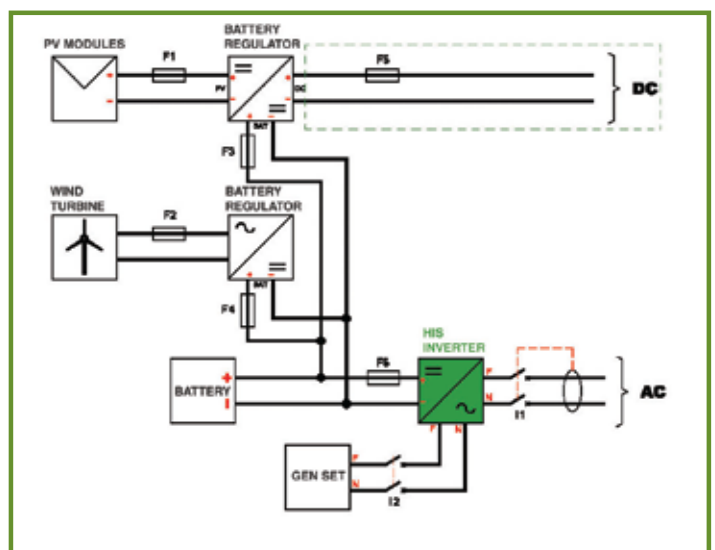

on-grid solar plants

mid voltage solar plants

hybrid generation

energy saving

telecom back up

wind energy



NON - STOP POWER



ELECTRICAL CHARACTERISTICS

Model	HIS 1,2	HIS 2,4	HIS 3,6	HIS 5	HIS 6	HIS 8
Reference	18718	18717	18716	18715	18714	18712
VA / Watts	1.2KVA/800W	2.4KVA/ 1600W	3.6KVA/ 2400W	5KVA/4000W	6KVA/6000	8KVA/8000
Nominal Input Voltage	220VAC(+20%~-45%) ; 120VAC(+20%~-45%) ; 50Hz(±10%) ; 60Hz z(±10%)					
Output Voltage	220VAC (230V or 240VAC readjustable by means of the LCD panel) 110 VAC (115V or 120VAC readjustable by means of the LCD panel)					
Voltage regulation	< 3% of the efficient value for the entire voltage range of the battery					
Output frequency	50Hz or 60Hz					
Frequency Regulation (Battery Mode)	± 0.1Hz					
Power Factor	0.8			1.0		
Waveform	Pure sinusoidal wave					
Efficiency	AC-AC >98% DC-AC > 75%	AC-AC >98% DC-AC > 75%			AC-AC >98% DC-AC > 80%	
Overload Protection	110% ~ 150% for 30sec. >150% for 200ms					
Typical Transfer Time	< 8 ms.					

BATTERY

Battery voltage	24V			48V		
Reserve time (with complete load)	In function of battery power range					
Maximum charging current (5 selectable steps)	> 30A			> 60A		
Maximum Solar charging current	50A					

GENERAL FEATURES

Acoustic Noise (dB)	<55 dBA (at 1m)					
Type of Protection	IP20					
Temperature Range	0°C ~ +40°C : 32 ~ 104°F					
Relative Humidity	0-95% without condensation					
Dimensions(WxHxD) mm	298x400x150	298x450x190	298x450x190	415x600x260	415x600x260	415x600x260
Weight (Kg)	14	21	23	49.2	51.4	53.6

STANDARDS

Certificates	CE Marking					
Directives	73/23/CEE-93/68/CEE 2004/108/CEE					
Standards	EN 62040-1-1 EN 62040-2, EN 61000-3-2, EN 61000-2-2, EN 55022					

These specifications may be changed without notice.